

EVI-D100 (NTSC) EVI-D100P (PAL)

Component / OEM



OUTLINE

The Sony EVI-D100 (NTSC) and EVI-D100P (PAL) video cameras are a great choice for any application that requires a high-quality color video camera with the flexibility of remote pan/tilt/zoom operation, all in a compact easy-to-use package. These high quality CCD cameras combine a high-speed, quiet pan/tilt with a wide angle of view and 40x zoom. Auto focus and automatic exposure control with back light compensation are fast and stable and can easily cope with difficult lighting conditions.

The EVI-D100/D100P models are ideal for applications such as videoconferencing, distance learning and corporate training, surveillance, sports, concerts and internet communications such as webcasting. Additional advantages are provided by easy to use presets, daisy-chaining capability and various digital picture effects.

FEATURES

- **High Speed, Wide Range Pan/Tilt**
The camera moves to a designated position quickly and immediately with a high pan/tilt speed.
Max. pan speed: 300 degrees/s (range ± 100 degrees)
Max. tilt speed: 125 degrees/s (range ± 25 degrees)
- **Quiet Operation**
Direct drive motors account for the gear-less structure of the camera, reducing the noise of pan/tilt motion drastically compared to conventional models.
- **40x Zoom Ratio (10x Optical + 4x Digital)**
The fast and stable auto focus zoom lens reaches impressive 40x zoom ratio.
- **Built-in Conversion Lens for Wide Angle View (65 degrees)**
The EVI-D100/D100P incorporates a newly developed wide-angle lens for wide field of view image capturing, making it ideal for use in small-sized rooms.
- **Six-position Presets with Battery Back-up**
An integral back-up battery stores presets of pan/tilt/zoom, focus position, AE mode and White Balance mode, even when the unit is powered off.
- **Auto Sleep Function**
The camera can be set to automatically turn off when not in use after a specified period of time.
- **Various Picture Effects**
Mirror Image, Still Image on Field Memory, Pastel Image, Negative/Positive Reversal, Enhanced Contrast, etc.
- **Multi-function IR Remote Commander® unit**
Easy to use supplied Remote Commander unit is useful for basic pan/tilt/zoom camera control.
- **RS-232C Serial Control by VISCA™ software**
All camera settings and pan/tilt/zoom functions can be controlled remotely via PC.
- **EVI-D30/D31 Emulation Mode**
The EVI-D100/D100P features an EVI-D30/D31 emulation mode that allows users to control their cameras using the same commands as those used for the EVI-D30/D31 cameras.*

* The EVI-D100/D100P may not emulate the EVI-D30/D31 perfectly due to the hardware differences between the two models.

SPECIFICATIONS

	EVI-D100	EVI-D100P
Video Signal	NTSC	PAL
Image Sensor	1/4 type Super HAD CCD™	
Effective Pixels	768 (H) x 494 (V)	752 (H) x 582 (V)
Horizontal Resolution	470 TV lines (Wide end)	460 TV lines (Wide end)
Lens	10x Optical Zoom, 40x with Digital Zoom, f = 3.1 to 31, F 1.8 to 2.9	
Horizontal Angle of View	6.6 to 65 degrees	
Minimum Object Distance	100 mm (Wide end), 600 mm (Tele end)	
Minimum Illumination	3.5 lx (F1.8)	
Auto Exposure	Auto/Manual/Priority AE, Exposure compensation, Back light Compensation	
Shutter Speed	1/4 to 1/10,000 s	1/3 to 1/10,000 s
White Balance	Auto, ATW, Manual, One Push, 3200K, 5800K	
Effects	Mirror Image, Still Image on Field Memory, Pastel Image, Negative/Positive Reversal, Sepia Image, Monochrome Image, Enhanced Contrast, Mosaic Image, Vertical Stretch, Horizontal Stretch, Motion Image on Still Image, Continuous Still Image, Motion Images on Binarized Still Image, After-image Lag of Moving Object	
S/N Ratio	More than 50 dB	
Pan/Tilt	Horizontal ± 100 degrees (Max speed 300 degrees/s), Vertical ± 25 degrees (Max speed 125 degrees/s) (in 0.07 degrees increments)	
Video Output	VBS, Y/C	
Power Requirements	DC 10.8 to 13.0 V	
Power Consumption	Max. 13.2 W (at 12 Vdc)	
Operating Temperature	0 to 40°C (32 to 104°F)	
Storage Temperature	-20 to 60°C (-4 to 140°F)	
Dimensions	4 1/2 x 4 3/4 x 5 1/4 inches (113 (W) x 120 (H) x 132 (D) mm)	
Mass	1 lb 14 oz (860 g)	
Supplied Accessories	AC adaptor, IR Remote Commander unit, Velcro tape, Operating instruction	

DIMENSIONS

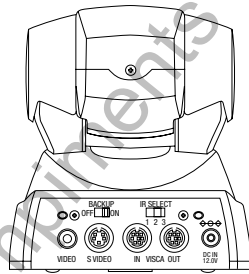
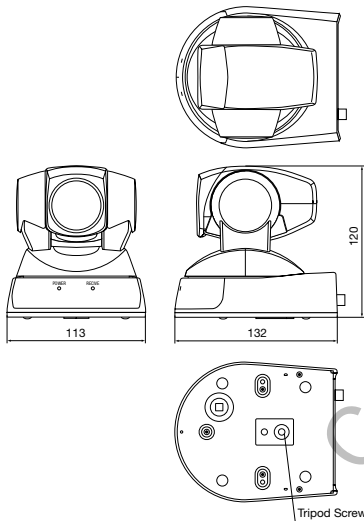

(unit: mm)

PAN/TILT RANGE

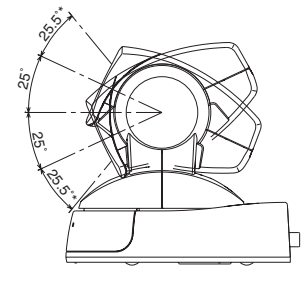
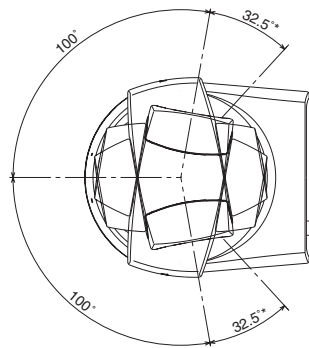

*Angle of view



- Sony Electronics Inc. (USA) HQ
- Sony of Canada Ltd. (CANADA)
- Sony Broadcast & Professional Europe HQ
 - Germany
 - France
 - UK
 - Nordic
 - Italy

1 Sony Drive, Park Ridge, NJ 07656
 115 Gordon Baker Rd, Toronto, Ontario M2H 3R6
 Schipholweg 275 1171 PK Badhoevedorp The Netherlands
 Hugo-Eckener-Strasse 20 D-50829 Koin
 16-26 rue Morel 92110 Clichy
 The Heights, Brooklands, Weybridge, Surrey KT13 0XW
 Per Albin Hanssons vag 20 S-214 32 Malmö Sweden
 Via Galileo Galilei 40 I-20092 Cinisello Balsamo, Milano

(TEL:+1-800-686-7669)
<http://www.sony.com/videocameras>
 (TEL:+1-416-499-1414) (FAX:+1-416-497-1774)
 (TEL:+31-20-44-99-351) (FAX:+31-20-44-99-333)
<http://www.sony-vision.com>
 (TEL:+49-221-537-8923) (FAX:+49-221-537-491)
 (TEL:+33-1-55-90-41-58) (FAX:+33-1-55-90-42-20)
 (TEL:+44-990-331122) (FAX:+44-1932-817011)
 (TEL:+46-40-190-800) (FAX:+46-40-190-450)
 (TEL:+39-02-61-83-84-26) (FAX:+39-02-618-38-402)

©2002 Sony Corporation. All rights reserved.
 Reproduction in whole or in part without written permission is prohibited.
 Design, features and specifications are subject to change without notice.
 Sony, Remote Commander, VISCA and Super HAD CCD are trademarks of Sony Corporation.