



English

29mm Cubic EIA
Analog B/W Camera

VCC-G20E30

Product Specification
& Operation Manual

CIS Corporation

Table of Contents

1. Scope of Application	3
2. Notice	3
3. Product Outline	3
4. System Connection Diagram	4
5. Specification	5
5.1. General Specification	5
5.2. Durability	7
5.3. Safety/Quality Standards	7
5.4. CCD Spectral Response (Representative Value)	8
5.5. Optical Black Layout	8
6. External Connector Pin Assignment	9
6.1. 12pins Circular Connector HR10-10R-12PA (73) (Hirose)	9
6.2. Switch Settings	9
7. Function	10
8. Dimensions	14
9. Timing Chart	15
9.1. Horizontal Synchronous Timing	15
9.2. Vertical Synchronous Timing (2:1 Interlace and Field integration)	15
9.3. Vertical Synchronous Timing (2:1 Interlace and Frame Integration)	16
9.4. Long Time Exposure Mode Timing (Restart, Reset Operation) Example 1 (at Frame Integration)	16
9.5. Long Time Exposure Mode Timing (Restart Reset Operation) Example 2 (at Frame Integration)	17
9.6. Long Time Exposure Mode Timing (Restart Reset Operation) Example 3 (at Field Integration)	17
9.7. External Trigger Operation Timing with Switch Setup (Reset). Trigger operation without External VD input.	18
9.8. External Trigger Operation Timing with Switch Setup (Non-Reset). Trigger operation with HD/VD input other than trigger input.	18
9.9. External Trigger Operation Timing by Pulse Width (Reset). Trigger operation without External VD input.	19
9.10. External Trigger Operation Timing by pulse width (Non-Reset). Trigger operation with HD/VD input other than trigger input.	19
10. Cases for Indemnity (Limited Warranty)	20
11. Handling Precautions	21

1. Scope of Application

This is to describe VCC-G20E30, EIA Analog B/W CCD camera.
All specifications contained herein are subject to change without prior notice.
Reproduction in whole or in part is prohibited.

2. Notice

The camera must not be used for any nuclear equipments or aerospace equipments with which mechanical failure or malfunction could result in serious bodily injury or loss of human life. Our warranty does not apply to damages or defects caused by irregular and/or abnormal use of the product. Please refer to Clause 11. Handling Precautions.

3. Product Outline

VCC-G20E30 is a high-resolution industrial B/W analog camera module utilizing a 1/3-inch TV format CCD. 380K pixels CCD image sensor with on-chip micro-lenses realizes high sensitivity and high resolution.

Key Features

Normal Speed & Double Speed Operation

The camera can operate in both normal speed and double speed. (Initial setting: Normal)

Sync. System

HD/VD External sync., External trigger input.

(HD/VD External sync. are automatically recognized.)

Add internal jumper resistor for HD/VD input 75 terminal.

Long Exposure (Restart-Reset)

Long exposure (restart reset system) operation is valid with random VD input (more than 2VD) and HD input.

External Trigger Shutter

Electronic shutter can be set either by trigger pulse width or by fixed switch.

For both shutter settings, reset mode and non-reset mode are available.

At reset mode, internal VD is reset after completion of exposure, and the images are output immediately. On the other hand, at non-reset mode, it waits external VD input after completion of exposure so that images can be output at random timing.

AGC

= 0.45 can be set by camera internal jumper resistance.

29mm Cubic in size

Its small size, 29mm cubic, and light weight, 44g, makes it a best match for use in embedded systems for image calibration and microscopic applications.

4. System Connection Diagram

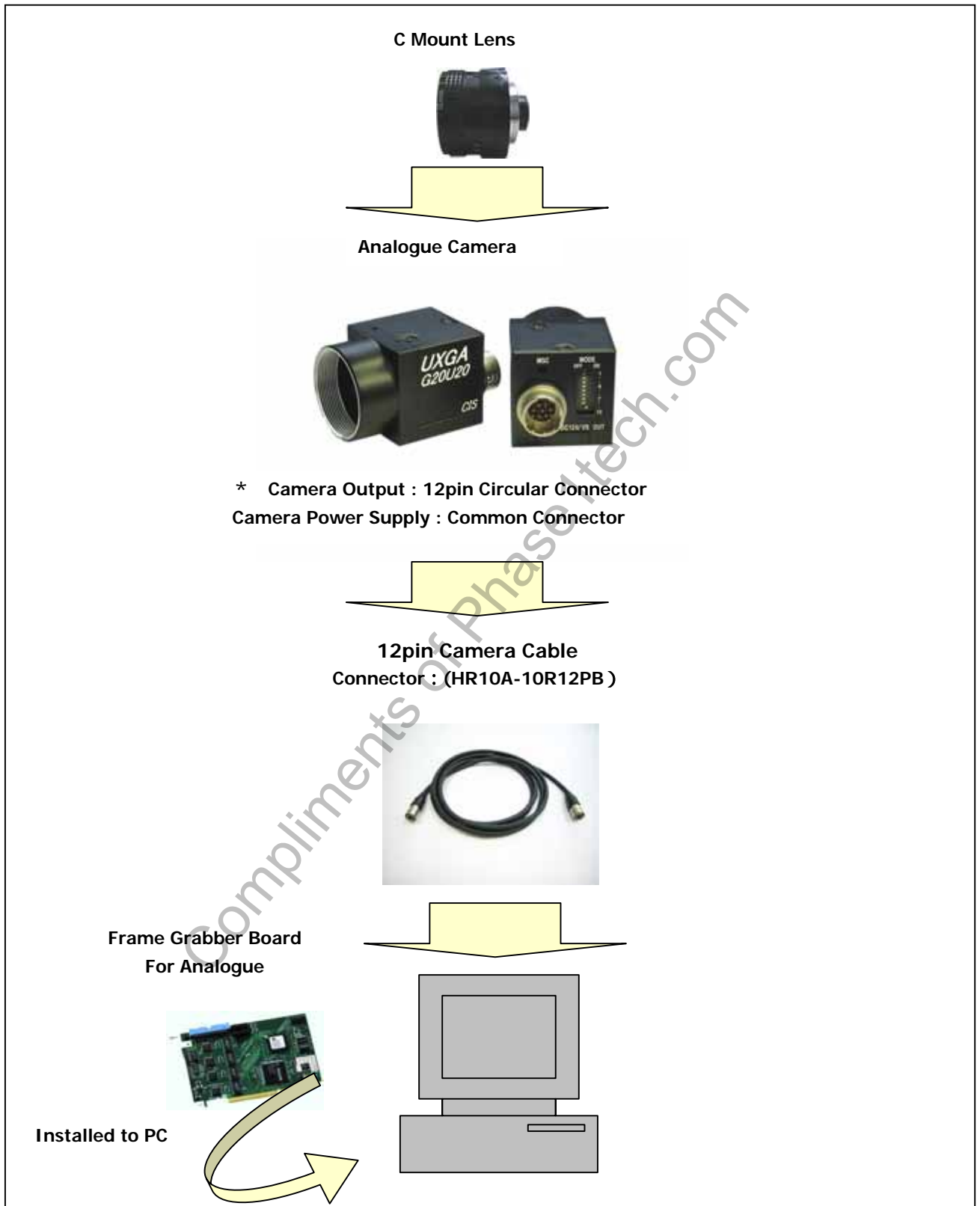

5. Specification

5.1. General Specification

Item	Specification	Remarks
Power consumption	1.6 W (Max power consumption is 1.8 W)	
Power requirements	DC +12V ± 10%	
Operation environment	Performance Guaranteed; 0 ~ + 40 with RH 20 ~ 80% Operation Guaranteed ; -5 ~ + 45 with RH20 ~ 80% Note: No condensation	
Storage environment	-25 ~ + 60 with RH 20 ~ 90% Note; No condensation	
Mass	44 g	
Dimensions	29(W) × 29(H) × 29(D)mm (not including protruding parts)	
Lens mount	C mount	
Flange back	Flange focal distance fixed	
Optical axis accuracy	Pixel center ±0.1 mm	
Pick up device	1/3" Interline Transfer B/W CCD Total pixel number 768 (H) × 494 (V) Effective pixel number 752 (H) × 485(V) Unit cell size 6.35 μm(H) × 7.4 μm(V)	EIA ICX408ALL (Sony)
Spectral response	Refer to 5.4. CCD Spectral response (representative value).	
S/N ratio	56 dB (Gain 0dB) for both normal speed and double speed	
Horizontal resolution	570 TV line	
Gain	Manual 0 ~ +12 dB AGC 0 ~ +12 dB	
Gamma	1.0 fixed	
Sensitivity	F8 400 lx (exposure 1/30, Gain 0dB, 3200 ° K)	
Minimum illumination	F1.4 1.0 lx (exposure 1/30, Gain Max, VS 50IRE)	
Synchronization System	Internal Sync. HD/VD External Sync. Input signal level: 2 ~ 5Vp-p, TTL Input Automatically switched by HD recognition. Frequency allowance: ± 1 % Jitter: under 20ns	Jumper resistance of 75 terminal

Item	Specification	Remarks
Scanning system Non-interlace scan	2:1 Interlace Normal Speed Horizontal frequency 15.734 KHz Vertical frequency 59.94 Hz Pixel clock 14.318 MHz Double Speed Horizontal frequency 31.468 KHz Vertical frequency 119.88 Hz Pixel clock 28.636 MHz	
Video output signal	Analog VS output 1.0V(p-p) Sync. negative, 75 unbalanced, DC connect White clip level; 820 ± 50mVp-p Setup level; 25 ± 10mVp-p Sync level; 290 ± 30mVp-p VS DC level; 500 ± 100mV	
Trigger input	Input signal Trigger signal shall be positive, rising edge. Input signal level; Low 0.5Vmax , High 4Vmin Input trigger width; 100us ~ 250ms	
Normal shutter operation	Normal Speed OFF, 1/125, 1/250, 1/500, 1/1000, 1/2000, 1/4000, 1/10000s Double Speed OFF, 1/250, 1/500, 1/1000, 1/2000, 1/4000, 1/8000, 1/20000s	
External trigger shutter operation	Normal Speed 1/100, 1/125, 1/250, 1/500, 1/1000, 1/2000, 1/4000, 1/10000s approx.1/4 ~ 1/10000sec. (with pulse width setting per 1HD) Double Speed 1/200, 1/250, 1/500, 1/1000, 1/2000, 1/4000, 1/8000, 1/20000s approx.1/4 ~ 1/20000sec. (with pulse width setting per 1HD) Jitter occurred between internal HD and trigger width will fluctuate exposure time by 1HD. To avoid this fluctuation, input HD signal.	Auto recognition of HD input
Field/Frame	Field Storage / Frame Storage	
Long Exposure (Restart / Reset)	External VD input cycle 262.5H ~ 500ms Field Storage / Frame Storage	

5.2. Durability

Item	Specification	Remarks
Vibration resistance	Acceleration 98m/S ² (10G) Vibration frequency 20 ~ 200Hz Sine wave Direction X Y Z 3 directions Testing time 20min for each direction No malfunction shall occur after testing the above.	
Shock resistance	Acceleration 490m/S ² (50G) Direction 6 directions	
Operation temperature	-5 ~ + 45 with RH 20 ~ 80% (No condensation) a) Leave the camera for 1 hour at the highest operation temperature (no condensation), turn on the power, and then the camera shall operate and meet the specifications. b) Leave the camera for 1 hour at the lowest operation temperature (no condensation), turn on the power, and then the camera shall operate and meet the specifications.	
Grounded mechanical chassis/Insulation	Mechanical chassis of VCC-G20E30 is grounded, therefore, use an insulated tripod adaptor when the camera shall be isolated.	

5.3. Safety/Quality Standards

- UL Standard
Conform to UL standard including materials and others.
- EMC
Conform to EN50081-2 (Emission)
Test standard EN55022:1998 Class A
Conform to EN50082-2 (Immunity)
Test standard EN61000-4-2 ~ 46
- RoHS
Conform to RoHS.
- FCC Conform to FCC Class A Digital Device
This device complies with Part 15 of the FCC Rules. Operation is subject to the following two conditions: (1) this device may not cause harmful interference, and (2) this device must accept any interference received, including interference that may cause undesired operation.

5.4. CCD Spectral Response (Representative Value)

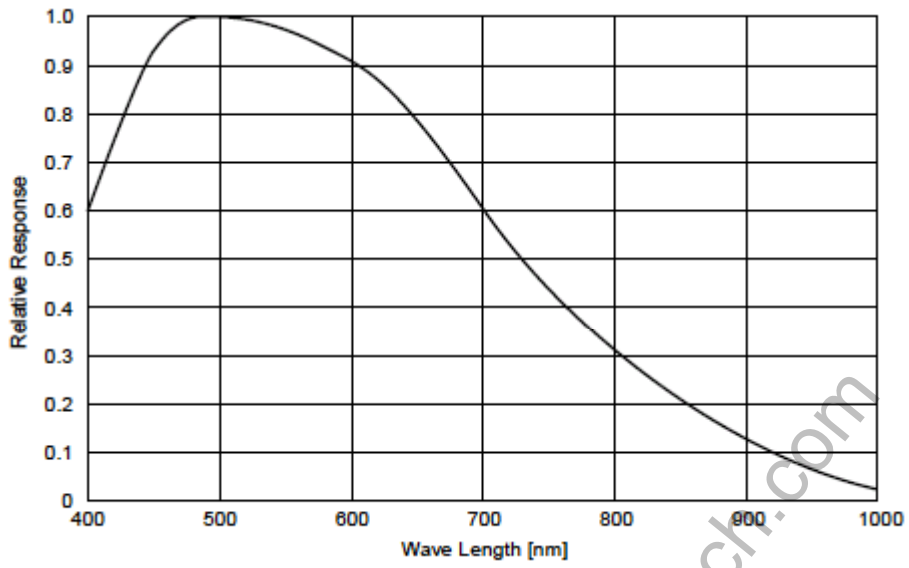

5.5. Optical Black Layout

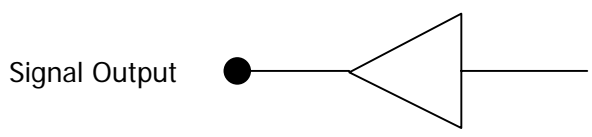
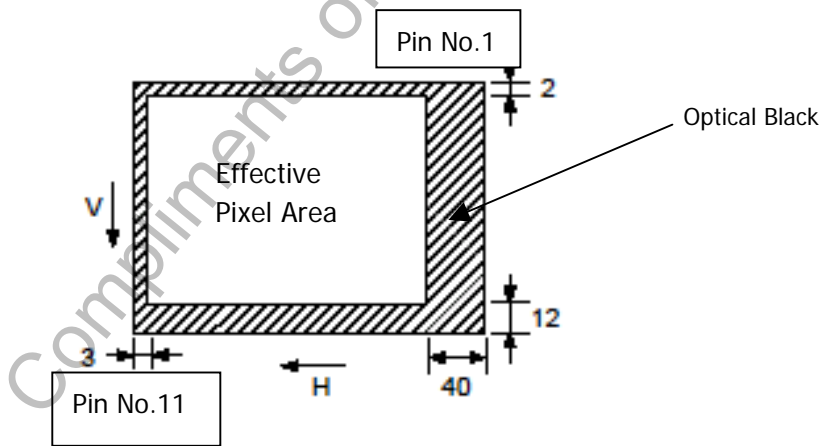

Top View
H:768 , V:494

6. External Connector Pin Assignment

6.1. 12pins Circular Connector HR10-10R-12PA (73) (Hirose)

Pin No.	
1	GND
2	Power IN +12V
3	GND
4	Video Out
5	GND
6	HD In/Out
7	VD In/Out
8	GND
9	NC
10	WEN OUT
11	TRIG IN
12	GND

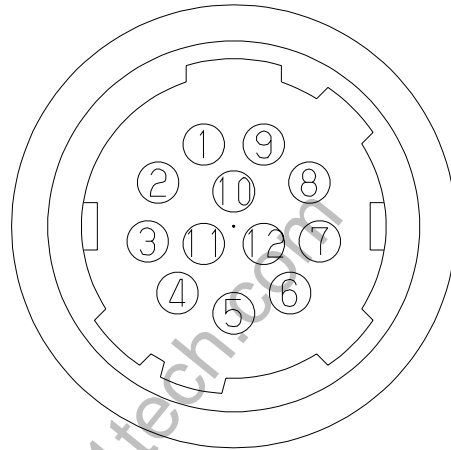

6.2. Switch Settings

Rear panel switch function 10bit DIP-Switch

1	E2	} Electronic Shutter Speed 3bit, 8step OFF ~ 1/10000sec, or long time exposure OFF ~ 1/4sec
2	E1	
3	E0	
4	FLD/FRM	} Field/Frame storage setting mode switch 1bit Function 3bit Normal/Long Time/Trigger (Non-Reset, Reset)
5	MODE2	
6	MODE1	
7	MODE0	} Gain (Manual/AGC) 1 bit
8	GAIN	
9	DOUBLE	} Normal speed / Double Speed setting switch 1bit HD/VD Input, Output HIROSE 12-6,7pin
10	IN/OUT	



OFF

indicates initial setting position.

Others;

HD/VD 75 impedance
=0.45

7. Function

Table of Settings

Function	Normal mode	Restart-Reset Operation	Reset Trigger Operation	Non-Reset Trigger Operation
Fixed Switch Shutter		×		
Field/Frame Operation	Field/Frame	Field/Frame	ODD Field	ODD Field
HD/VD Sync Output	HD/VD Out	X	HD/VD Out	X
External Sync Input	HD/VD In	HD/VD In	HD In	HD/VD In

Normal mode

EIA Compliance. 2:1 Interlace (Field/Frame) successive video out signals, without trigger input, is the normal mode setting. Normal shutter operation and HD/VD external sync input function is valid using rear fixed switch. Field storage setting is recommended to get double sensitivity compared to frame storage setting.

Long time exposure operation, Restart-reset mode

In this mode, one picture image is read-out inputting EXT VD over 1VD: 262.5H at any timing and adding EXT HD externally. This mode is effective when sensitivity is insufficient with normal exposure time, and/or when movement locus of shooting object shall be indicated. Since exposure time depends on the input frequency of EXT VD, shutter settings with rear switch will be invalid.

External trigger shutter operation by switch settings (Reset mode, Non-reset mode)

This is the trigger operation in which exposure time (shutter value) can be set by rear fixed switch. WEN signals will be "Level H" in image effective field period.

- Reset mode

EXT HD can be input but external VD must not be input.

As soon as internal SYNC VD is reset after exposure completion, read-out starts, therefore, video signals are output at the shortest timing. To avoid 1HD fluctuation caused by 1HD jitter between trigger input and exposure starting point, add EXT HD input.

- Non-reset mode

Falling edge of EXT VD and EXT HD signal phase must be matched.

Signal read-out starts after waiting for EXT VD input, therefore, video signals are output at any timing.

However, trigger input cycle will be longer than the one of reset mode.

External Trigger Operation by pulse width settings (Reset mode, Non-reset mode)

This is the trigger operation to set exposure time (shutter value) by trigger input pulse width.

Trigger pulse width shall be 100us ~ 250ms or more than 1HD ~ 250ms.

Shutter can be controlled by 1HD.

Approx. exposure time

At Normal Speed: Exposure Time = trigger pulse width (nHD) + 33.5us (HD = 63.56 us)

At Double Speed: Exposure Time = trigger pulse width (nHD) + 16.7us (HD = 31.78 us)

When trigger pulse is less than 1HD, ignore its time.

- Reset mode

EXT HD can be input but external VD must not be input.

As soon as internal SYNC VD is reset after exposure completion, read-out starts, therefore, video signals are output at the shortest timing. To avoid 1HD fluctuation caused by 1HD jitter between trigger input and exposure starting point, add EXT HD input.

- Non-reset mode

Falling edge of EXT VD and EXT HD signal phase must be matched.

Signal read-out starts after waiting for EXT VD input, therefore, video signals are output at any timing.

However, trigger input cycle will be longer than the one of reset mode.

Rear Fixed Electronic Shutter Switch SW1, SW2, SW3

E2	E1	E0	Shutter Value	Actual Time at Normal Speed
1	2	3		
OFF	OFF	OFF	OFF	16.67 ms (Field Storage), 33.33 ms (Frame Storage)
			1/100 sec	10.0 ms (Trigger Operation)
OFF	OFF	ON	1/125 sec	8.0 ms
OFF	ON	OFF	1/250 sec	4.0 ms
OFF	ON	ON	1/500 sec	2.0 ms
ON	OFF	OFF	1/1000 sec	987 us
ON	OFF	ON	1/2000 sec	478 us
ON	ON	OFF	1/4000 sec	224 us
ON	ON	ON	1/10000 sec	97 us

E2	E1	E0	Shutter Value	Actual Time at Double Speed
1	2	3		
OFF	OFF	OFF	OFF	8.33ms (Field Storage), 16.67ms (Frame Storage)
			1/200 sec	5.0 ms (Trigger Operation)
OFF	OFF	ON	1/250 sec	4.0 ms
OFF	ON	OFF	1/500 sec	2.0 ms
OFF	ON	ON	1/1000 sec	1.0 ms
ON	OFF	OFF	1/2000 sec	493 us
ON	OFF	ON	1/4000 sec	239 us
ON	ON	OFF	1/8000 sec	112 us
ON	ON	ON	1/20000 sec	49 us

Rear Switch for Filed/Frame mode Change SW4

OFF	Field	Field Storage Mode
ON	Frame	Frame Storage Mode

Rear Switch for Operation Mode Change SW5, SW6, SW7

Mode2	Mode1	Mode0	Setting Mode
5	6	7	
OFF	OFF	OFF	Normal Interlace Operation
OFF	ON	ON	Long Time Exposure Operation (Restart, Reset)
ON	OFF	OFF	External Trigger Operation by Switch Setting (Rest Mode)
ON	OFF	ON	External Trigger Operation by Switch Setting (Non-reset Mode)
ON	ON	OFF	External Trigger Operation by Pulse Width Setting (Reset Mode)
ON	ON	ON	External Trigger Operation by Pulse Width Setting (Non-reset Mode)

Do not set the mode other than those above.

Rear Switch for Gain Setting SW8

OFF	Manual Gain
ON	AGC Gain

Rear Switch for Speed Change SW9

OFF	Normal Speed, Pixel Clock 14.318 MHz (EIA)
ON	Double Speed , Pixel Clock 28.636 MHz When switching the pixel clock, re-boot camera power.

Rear Switch for HD/VD Input Output SW10

OFF	HD/VD Output	Valid only at internal sync operation
ON	HD/VD Input	Valid at normal operation, long time exposure operation, and External trigger operation (non-reset)
	HD Input	Valid at External trigger operation (reset)

External HD/VD input phase

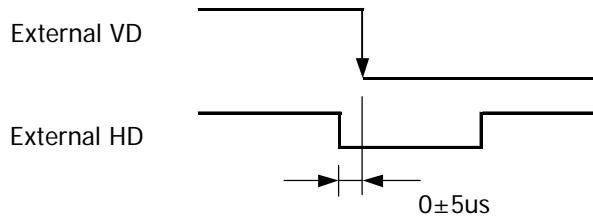

Trigger input signal and exposure time (Pulse width shutter)
Start and end of exposure time depend on internal HD signals.

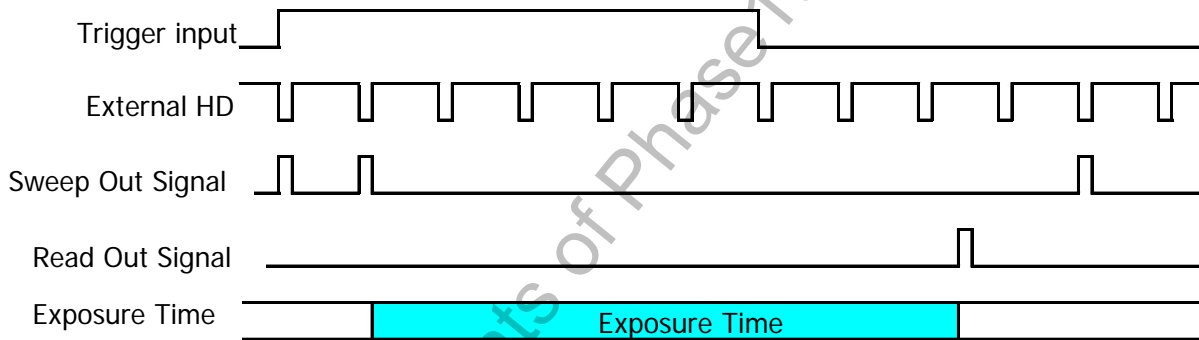

Compliments of Phase1tech.com

9. Timing Chart

9.1. Horizontal Synchronous Timing

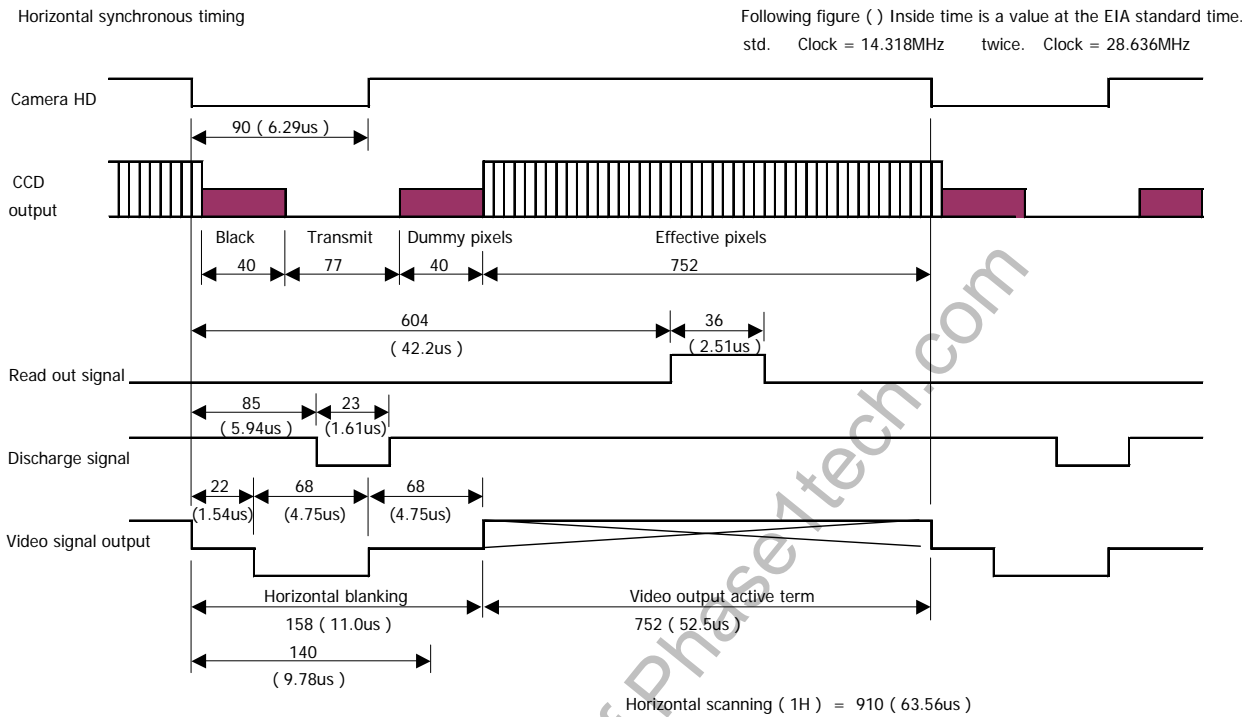

9.2. Vertical Synchronous Timing (2:1 Interlace and Field integration)

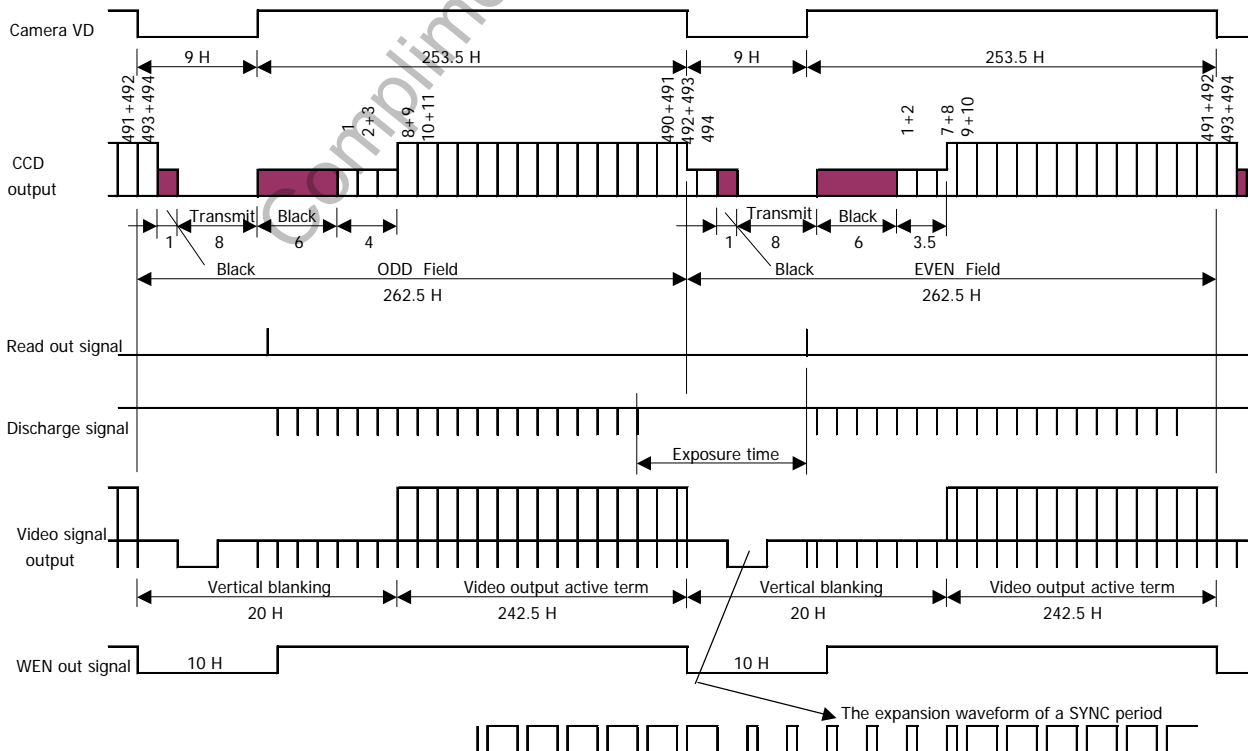

9.3. Vertical Synchronous Timing (2:1 Interlace and Frame Integration)

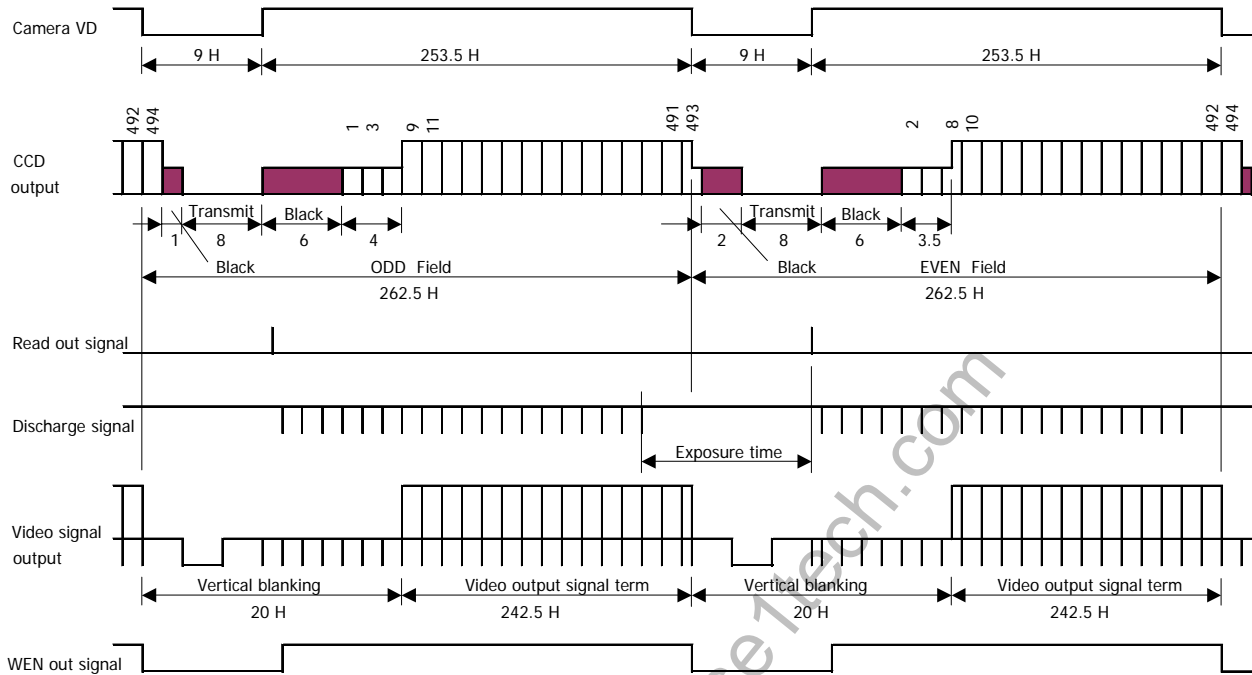

9.4. Long Time Exposure Mode Timing (Restart, Reset Operation) Example 1 (at Frame Integration)

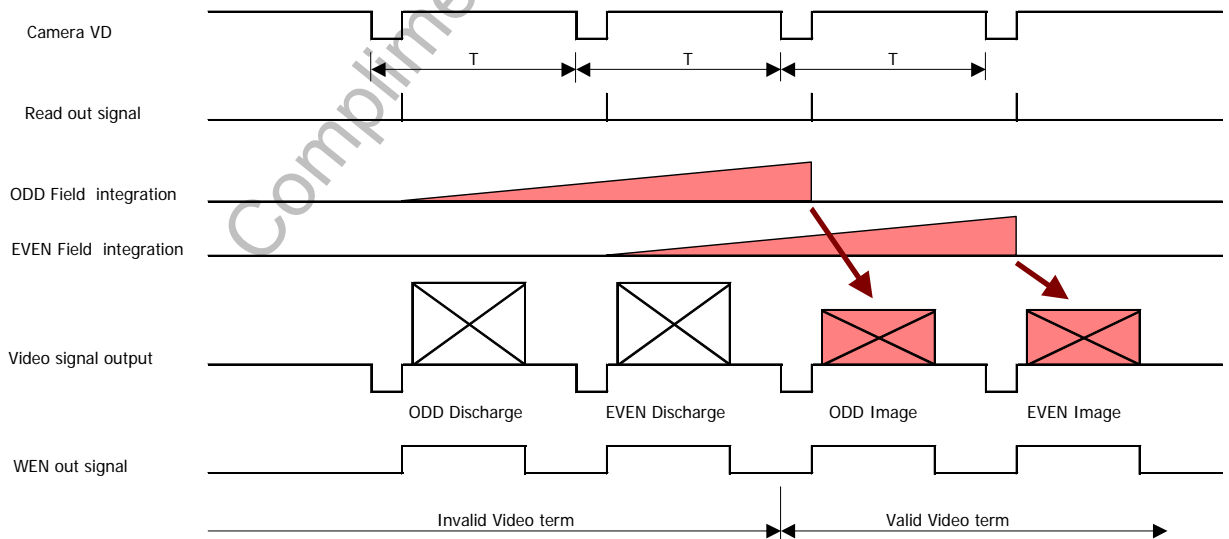

- 1 Please be sure to input External HD/VD signals.
- 2 ODD/EVEN field is determined by the phase of External HD/VD signals.
- 3 Please set the Exposure time T as more than 262.5H and 0.5 seconds or less.

9.5. Long Time Exposure Mode Timing (Restart Reset Operation) Example 2 (at Frame Integration)

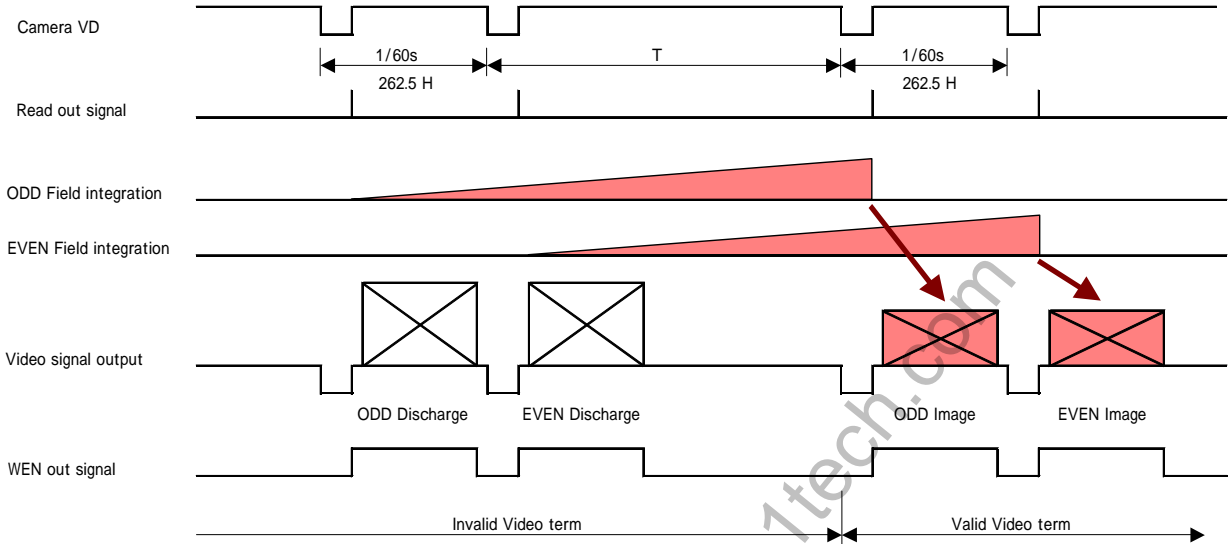

- 1 Please be sure to input External HD/VD signals.
- 2 ODD/EVEN field is determined by the phase of External HD/VD signals.
- 3 Please set the Exposure time T as more than 262.5H and 0.5 seconds or less.

9.6. Long Time Exposure Mode Timing (Restart Reset Operation) Example 3 (at Field Integration)

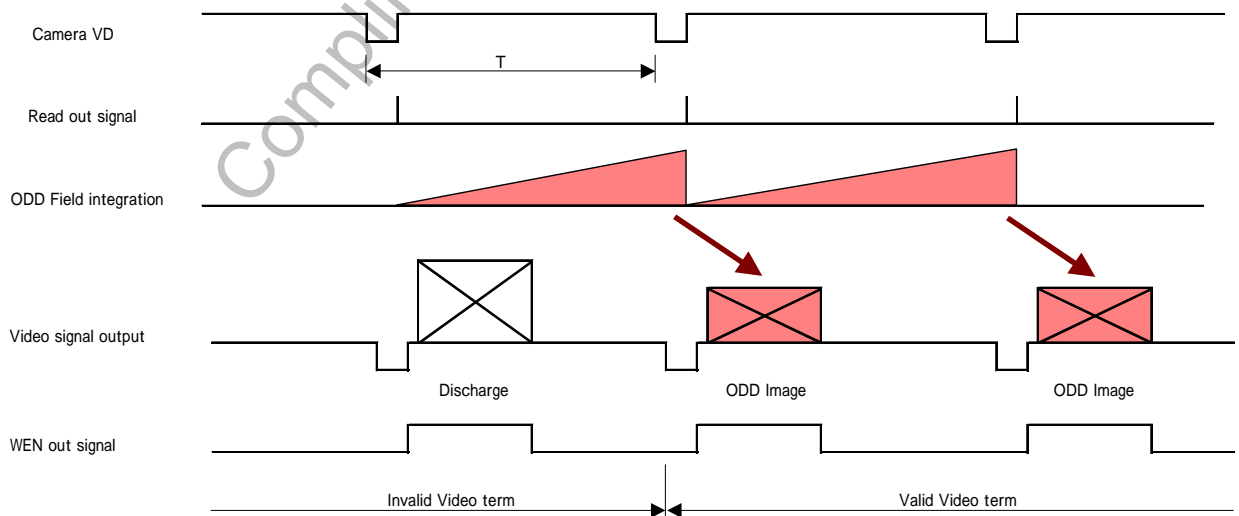

- 1 Please be sure to input External HD/VD signals.
- 2 ODD/EVEN field is determined by the phase of External HD/VD signals.
- 3 Please set the Exposure time T as more than 262.5H and 0.5 seconds or less.

9.7. External Trigger Operation Timing with Switch Setup (Reset). Trigger operation without External VD input.

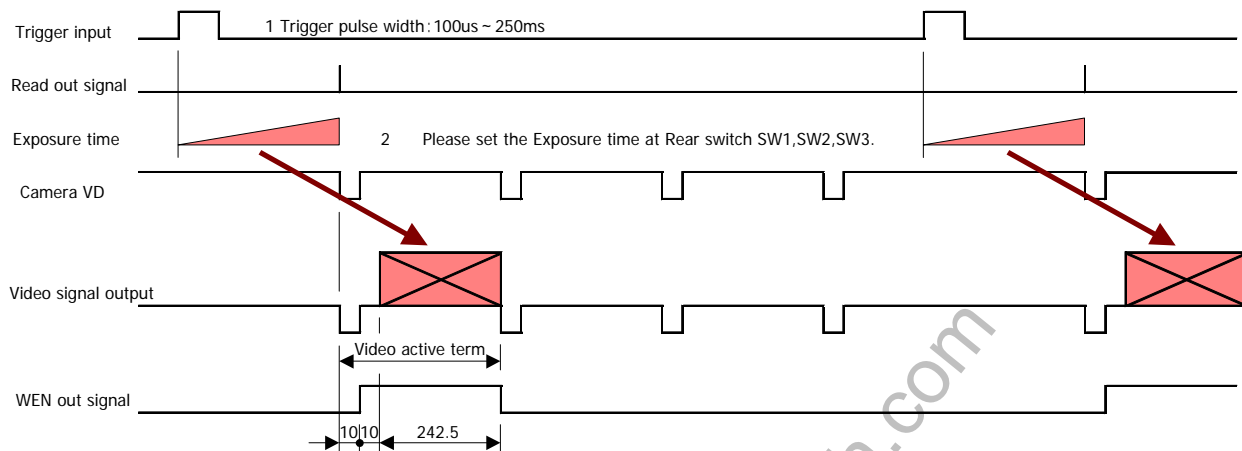

- 1 Please use the Input interval more than $1V=262.5H$ and trigger input width from 100us to 250ms. An image is outputted to the shortest timing by the reset action.
- 2 Exposure time is determined by 3bits SW1,SW2,SW3 on the rear panel. However, the Video output level changes with an integration mode setup of the rear panel SW4.
- 3 Jitter of a H occurs in exposure start after a trigger input for the sake of the convenience by which taking in is started synchronizing with Internal HD. When you make Jitter cancel, please input External HD.
- 4 In a reset action, an External VD input becomes intact.

9.8. External Trigger Operation Timing with Switch Setup (Non-Reset). Trigger operation with HD/VD input other than trigger input.

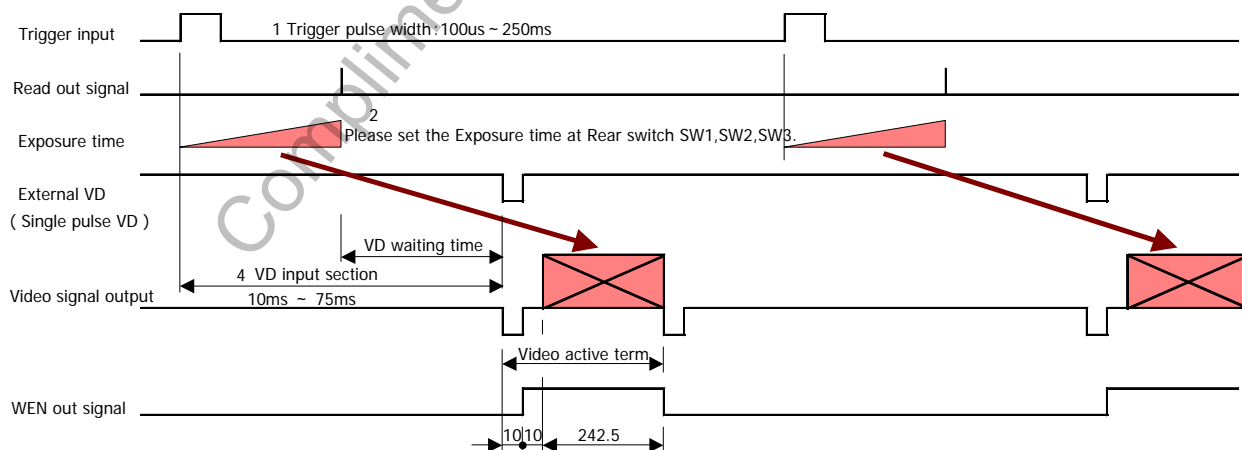

- 1 Please use the Input interval above (Exposure time + 1 field (effective image period) + VD waiting time) and trigger input width from 100us to 250ms.
- 2 Exposure time is determined by 3bits SW1,SW2,SW3 on the rear panel. However, the Video output level changes with an integration mode setup of the rear panel SW4.
- 3 The external input of EXT_VD and EXT_HD should surely unite the phase of a falling waveform.
- 4 Surely, since a Trigger signal rises, the input of EXT_VD should go to the section for 10 to 75ms.

9.9. External Trigger Operation Timing by Pulse Width (Reset). Trigger operation without External VD input.

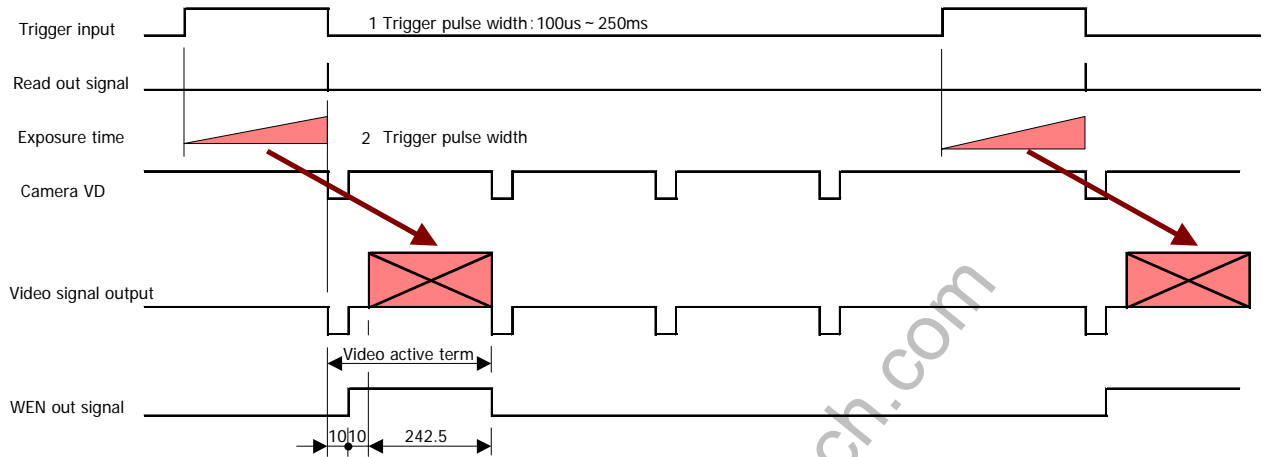

- 1 Please use the Input interval more than $1V=262.5H$ and trigger input width from 100us to 250ms. An image is outputted to the shortest timing by the reset action.
- 2 Exposure time is determined by the input width of Trigger. about, $Exposure\ time = Trigger\ width\ (nH) + 33.5\ \mu s$
- 3 Jitter of a H occurs in exposure start after a trigger input for the sake of the convenience by which taking in is started synchronizing with Internal HD. When you make Jitter cancel, please input External HD.
- 4 In a reset action, an External VD input becomes intact.

9.10. External Trigger Operation Timing by pulse width (Non-Reset). Trigger operation with HD/VD input other than trigger input.

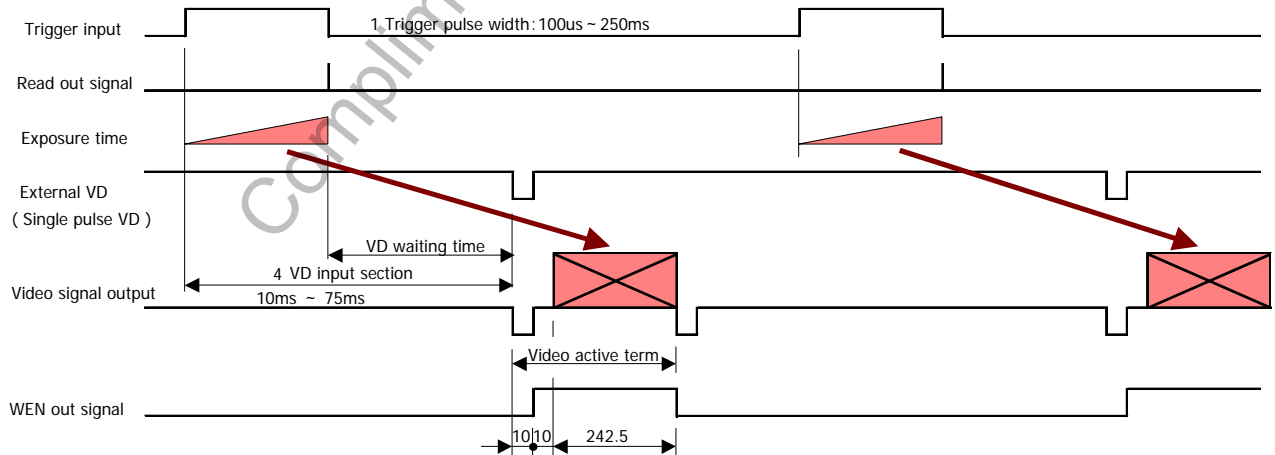

- 1 Please use the Input interval above (Exposure time +1 field (effective image period) + VD waiting time) and trigger input width from 100us to 250ms.
- 2 Exposure time is determined by the input width of Trigger. about, $Exposure\ time = Trigger\ width\ (nH) + 33.5\ \mu s$
- 3 The external input of EXT_VD and EXT_HD should surely unite the phase of a falling waveform.
- 4 Surely, since a Trigger signal rises, the input of EXT_VD should go to the section for 10 to 75ms.

10. Cases for Indemnity (Limited Warranty)

We shall be exempted from taking responsibility and held harmless for damage or losses incurred by the user in the following cases.

- In case damage or losses are caused by fire, earthquake, or other acts of God, acts by third party, deliberate or accidental misuse by the user, or use under extreme operating conditions.
- In case indirect, additional, consequential damages (loss of business interests, suspension of business activities) are incurred as result of malfunction or non-function of the equipment, we shall be exempted from responsibility for such damages.
- In case damage or losses are caused by failure to observe the information contained in the instructions in this product specification & operation manual.
- In case damage or losses are caused by use contrary to the instructions in this product specification & operation manual.
- In case damage or losses are caused by malfunction or other problems resulting from use of equipment or software that is not specified.
- In case damage or losses are caused by repair or modification conducted by the customer or any unauthorized third party (such as an unauthorized service representative).
- Expenses we bear on this product shall be limited to the individual price of the product.

11. Handling Precautions

【Important】 Please observe all warnings and cautions stated below. Our warranty does not apply to damages or malfunctions caused by neglecting these precautions.

- Do not use or store the camera in the following extreme conditions:
 - Extremely dusty or humid places.
 - Extremely hot or cold places (Operating temperature -5 to + 45).
 - Close to generators of powerful electromagnetic radiation such as radio or TV transmitters.
 - Places subject to fluorescent light reflections.
 - Places subject to unstable (flickering, etc.) lighting conditions.
 - Places subject to strong vibration.
- Remove dust or dirt on the surface of the lens with a blower.
- Do not apply excessive force or static electricity that could damage the camera.
- Do not shoot direct images that are extremely bright (eg., light source, sun, etc.), and when camera is not in use, put the lens cap on.
- Follow the instructions for connecting the camera. Improper connection may cause damages not only to the camera but also to the connected devices.
- Confirm the mutual ground potential carefully and then connect the camera to monitors or computers. AC leaks from the connected devices may cause damages or destroy the camera.
- Do not apply excessive voltage. (Use only the specified voltage.) Unstable or improper power supply voltage may cause damages or malfunction of the camera.
- Make sure that the camera and peripheral equipments are properly connected before turning the camera on. Especially in INT/EXT sync signal settings, improper connection may cause damages to the camera and the connected devices.
- Make sure to wait for over 2 seconds before rebooting.
- In case of abnormal operation, contact the distributor from whom you purchased the product.