

Piranha 2 P2-4x-xxx40 (7 μ m)

Line Scan Cameras



Key Features

- 160 MHz throughput
- Resolutions from 4k to 8k
- High responsivity
- Single 12 V to 15 V power supply
- Slimline: 76 mm x 105 mm x 50 mm (8k)
- Standard: 85 mm x 85 mm x 53.7 mm (4k, 6k, 8k)

Programmability

- Programmable pixel to pixel correction
- Adjustable analog and digital gain and offset
- 8 or 10 bit selectable output
- Adjustable integration time and line rate

Typical Applications

- Flat panel display inspection
- Printed circuit board inspection
- High performance document scanning/image lift
- Postal/parcel sorting
- General machine vision

Overview

Medium Camera Link, 7 μ m pixels and resolution from 4k to 8k with proven performance.

Piranha 2 delivers superb performance with a wide selection of resolutions. Medium Camera Link with four 8 or 10 bit outputs at 40 MHz deliver 160 MHz throughput, and boosted responsivity means the Piranha 2 needs less light. Our 4 tap, 7 μ m pixel models are available in resolutions from 4k to 8k.

The compact design is shallow and the new 8k slimline design (76 mm x 105 mm x 50 mm) is even narrower than our original Piranha2 products for easier mounting and minimized optical path. Cabling and interface are simplified with the Camera Link™ high speed serial standard. The camera is more sensitive, but still provides quieter, more uniform output thanks to CDS (correlated double sampling) and embedded flat field correction algorithms. Gain and offset are fully programmable for each output channel, and the camera can output test patterns for cable/system troubleshooting.

Specifications

Resolution	4096 / 6144 / 8192
Data Rate	4 x 40 MHz
Max. Line/Frame Rate	36 / 24 / 18 kHz
Pixel Size	7 μ m
Data Format	8, 10 bit
Output	Medium Camera Link
Lens Mount	M72 x 0.75, F mount
Responsivity	38 DN/(nJ/cm ²) @ 10 dB
Dynamic Range	54 dB
Nominal Gain Range	\pm 10 dB
Size	85 x 85 x 53.7 / 76 x 105 x 50 mm
Mass	< 450 g
Operating Temp	10 °C to 50 °C
Power Supply	12 V to 15 V
Power Dissipation	< 10 W
Regulatory Compliance	CE
Control	MDR26 Camera Link
Data	Shared with Control
Power	Hirose HR10 6 pin
Example Part Number	P2-42-06K40

Piranha 2 P2-4x-xxx40 (7 μm)

Line Scan Cameras

With established performance and wide customer base, the Piranha 2 is the camera generation known to have brought line scan performance to the next level.

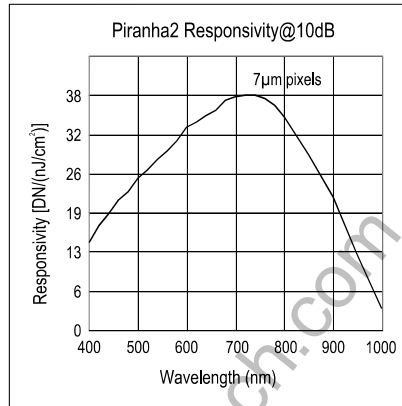

STANDARD 8K 4 TAP WITH LARGE FORMAT ADAPTER STANDARD 4K/6K 4 TAP WITH F MOUNT

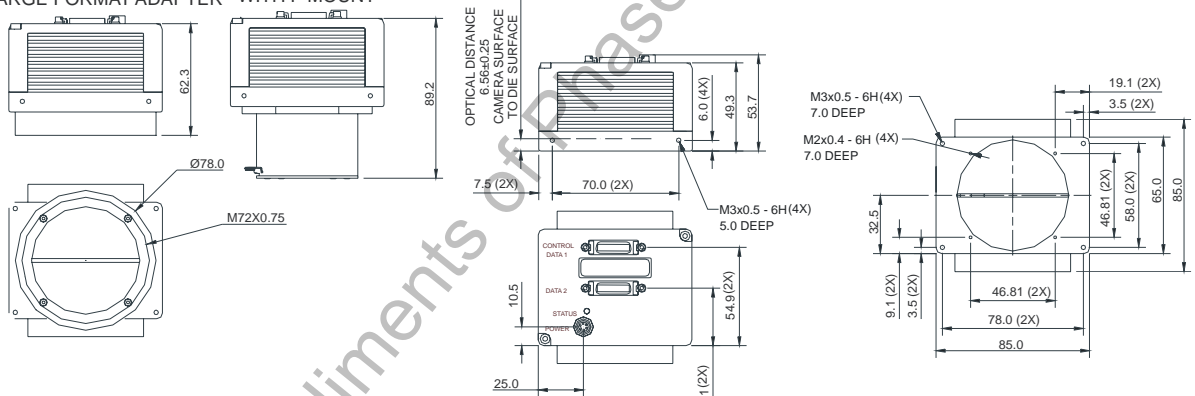

SLIMLINE 8K 4 TAP WITH LARGE FORMAT ADAPTER

