

Mini-CameraLink Ultra-Compact Progressive Scan Black and White CCD Camera

KP-F200SCL KP-F30SCL



Ultra Compact 29 mm cube camera with mini SDR type CameraLink connector.

- The small SDR connector for digital output allows the camera size to be drastically reduced to a 29 mm cube. This reduction in camera size permits use in vision systems where space is at a premium.

High resolution and high frame rates

- **KP-F200SCL** 2.01 million pixels for high resolution (UXGA) at 15 frames per second. Designed for High Resolution Inspection.
- **KP-F30SCL** 330,000 pixels for a high frame rate of 60 frames per second at standard resolution (VGA). Designed for high speed inspection.

Remote operation by serial control

- Selectable 10 or 8 bit per pixel output at the CameraLink connector.
- Variable Speed Shutter selectable in 1H steps.
- Frame on demand function
- Remote control

Connection using optical cable transmission for long distance operation.

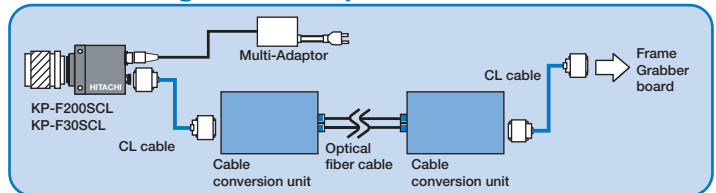

Comparison with conventional CameraLink

The conventional CameraLink output system model

KP-F200SCL
KP-F30SCL
(Mini-CameraLink)



Small SDR (Mini-CameraLink) Connector [24.4 x 9.0 mm]



Conventional MDR-26 CameraLink Connector [39.7 x 12.9 mm]

Main Specifications

	KP-F200SCL	KP-F30SCL
Imaging device	1/1.8-inch interline CCD	1/3-inch interline CCD
Total pixels	1688 (H) x 1248 (V)	692 (H) x 504 (V)
Effective pixels	1628 (H) x 1236 (V)	659 (H) x 494 (V)
Pixel pitch	4.4 μm (H) x 4.4 μm (V) [square lattice]	7.4 μm (H) x 7.4 μm (V) [square lattice]
Imaging area	7.16 mm (H) x 5.44 mm (V)	4.88 mm (H) x 3.66 mm (V)
Scanning system	Non-interlaced	
Aspect ratio	4 : 3	
Frame rate	15frames/second (full pixel readout)	60frames/second (full pixel readout)
Scanning frequency	Horizontal: 18.75 kHz Vertical: 15 Hz	Horizontal: 31.468 kHz Vertical: 60 Hz
Synchronization	Internal	
Lens mount	C mount	
Flange focal distance	17.526 mm	
Video output	Digital output Camera Link Data : Base configuration 10bit x 1 CLK=36.000MHz	Digital output Camera Link Data : Base configuration 10bit x 1 CLK=24.5454MHz
Resolution	Horizontal 1200 lines Vertical 1200 lines	Horizontal 500 lines Vertical 490 lines
Electronic shutter speed	1/15, 1/60, 1/100, 1/250, 1/1000, 1/2000, 2000, 1/10000, 1/50000 second factory setting is off (1/15 second) or 547 steps changeable by variable shutter (minimum 1/100000 seconds)	1/60, 1/250, 1/500, 1/1000, 1/2000, 1/4000, 1/10000, 1/50000 second factory setting is off (1/60 second) or 1280 steps changeable by variable shutter (minimum 1/100000 seconds)
Gamma compensation	$\gamma = 1$	
Frame on demand	Remote setting (fixed shutter, and one trigger) Factory setting is all off	Remote setting (fixed shutter, one trigger, and reset control mode) Factory setting is all off.
Power supply voltage	DC12V ± 1V	
Current consumption	Approx. 210 mA	Approx. 160 mA
Ambient	operating: 0 to +40°C (+32 to ; 104°F), less than 90 % RH storage: -10 to +50°C (+14 to +122°F), less than 70 % RH *If operated continuously, be sure to use at less than +40°C (104°F) for long term stable performance.	
Vibration endurance	98 m/s ² (10 to 60Hz, amplitude: 0.98mm constant / 60 to 200Hz, amplitude: variable) (10 to 150Hz, sweep: 1 min, XYZ, 30 min)	
Shock endurance	686 m/s ² (Drop test, once each top, bottom, left and right)	
External dimensions	29(W) x 29(H) x 29(D) mm	
Mass	Approx. 53 g	
Remote control		
Signal system	1. Control system: Start-stop synchronization system 2. Transmission rate: 9600 bps 3. Data length: 8 bits 4. Start bit: 1 5. Stop bits: 1 6. Parity: None 7. Bit transfer: LSB first	
Communications control system	Full control by remote control software, data send/receive by text data transfer to camera microprocessor (BSC system handshake)	
Control items	1. Shutter speed 2. FD (frame on demand): On/off 3. Mode: Fixed shutter, One trigger, Reset control mode(KP-F30SCL only) 4. Digital output: 8bit/10bit 5. Gain: 463steps (1 step: Approx. 0.04dB) 6. HD reset: On/off (factory setting is on) 7. Partial scan	

Spectral sensitivity characteristic

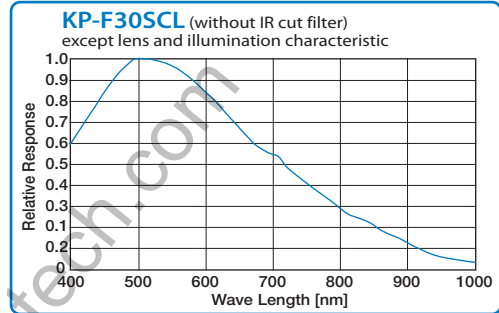
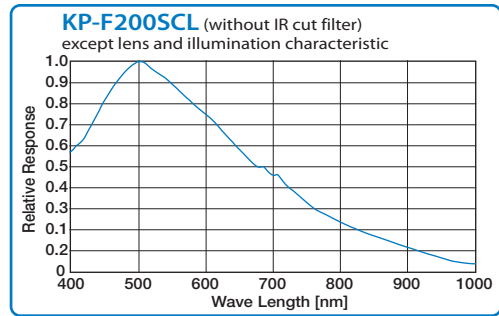

Dimensions

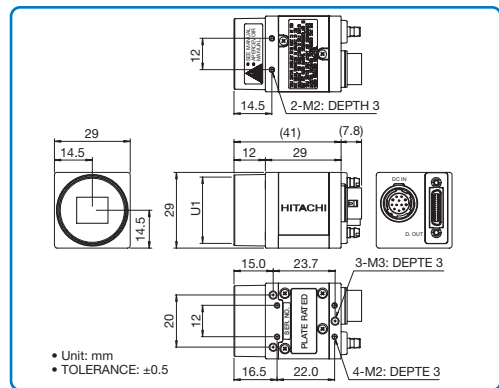

Optional accessories

12 pin plug	HR10A-10P-12S(01)	
Multi-adaptor	JC-100	
Dummy glass (AR coated)	ARC1214	
Camera cable	Molded type	Shield type
	2 m	C-201-KSM C-201-KSS
	5 m	C-501-KSM C-501-KSS
	10 m	C-102-KSM C-102-KSS
	*In the CE Marking region, use the shield type.	
Tripod adaptor	TA-F200	

CAUTION: To ensure safe operation, please read the instruction manual before using this product.

These Specifications are subject to change without notice.

Hitachi Kokusai Electric Inc.

Head Office : 4-14-1, Sotokanda, Chiyoda-ku, Tokyo 101-8980, Japan
Phone : +81(0) 3-6734-9432, Fax : +81(0) 3-5209-5942
URL : <http://www.h-kokusai.com>

Beijing Office : Beijing Fortune Building 5, Dong San Huan Bei-lu, Chao Yang District, Beijing, 100029 China
Phone : +86(0) 10-6590-8753/8756, Fax : +86(0) 10-6590-8757

Hitachi Kokusai Electric America, Ltd. URL : <http://hitachikokusai.us>

Headquarters and : 150 Crossways Park Drive, Woodbury, New York 11797, U. S. A.

Northeast Office : Phone : (+1) 516-921-7200, Fax : (+1) 516-496-3718

West Office : 371 Van Ness Way, Suite 120 Torrance, CA, 90501, U. S. A.

Phone : (+1) 310-328-6116, Fax : (+1) 310-328-6252

Midwest Sales : Phone : (+1) 330-334-4115, Fax : (+1) 516-496-3718

Service (+1) 989-345-5379

South Sales : Service (+1) 256-774-3777

Paris Center : Phone : (+1) 516-682-4435, Fax : (+1) 516-921-0993

Latin Sales : Phone : (+1) 516-682-4420, Fax : (+1) 516-496-3718

Hitachi Kokusai Electric Canada, Ltd. URL : www.hitachikokusai.ca

Head Office : 1 Select Avenue Unit#11 Scarborough, Ontario M1V 5J3, Canada

Phone : (+1) 416-299-5900, Fax : (+1) 416-299-0450

Eastern Office : 5795 Chemin St. Francois St. Laurent, Quebec H4S 1B6, Canada

Phone : (+1) 514-332-6687, Fax : (+1) 514-335-1664

Hitachi Kokusai Electric Europe GmbH

Head Office : Weiskircher Straße 88, Jügesheim D-63110 Rodgau, Germany
Phone : +49(0) 6106-69920, Fax : +49(0) 6106-16906
URL : www.hitachi-ke-eu.com
General email address : info@hitachi-ke-eu.com

Hitachi Kokusai Electric U.K. Ltd.

Head Office : Windsor House, Britannia Road, Waltham Cross, Hertfordshire EN8 7NX, United Kingdom
Phone : +44(0) 845-121-2177, Fax : +44(0) 845-121-2180
Leeds Office : Brookfield House, Selby Road, Garforth, Leeds LS25 1NB, United Kingdom
Phone : +44(0) 113-287-4400, Fax : +44(0) 113-287-4260
URL : www.hitachi-ke-eu.com
General email address : info@hitachi-ke-eu.com



CERTIFICATE No.
JMI-0062
ISO 9001/BS 5750Pt1
EN 29001/JIS Z9901