



For FA/Machine Vision
Fixed Focal

HF12.5SA-1

Applicable camera (model)

1	2/3	1/2	1/3	1/4
---	-----	-----	-----	-----

- FIXED
Fixed Focal
- 5 Mega
For Megapixel Camera
- MANUAL
Manual Iris
- C-mt
C Mount
- METAL
Metal Mount
- F1.4
Wide Aperture Rate

NEW



- High-resolution design, providing support for up to 5 megapixel camera resolution.
- Rear focusing system provides improved performance in macro photography.
- Wide-aperture (F1.4) design achieves clear images under low light intensity.
- Enhanced image recognition accuracy achieved by reduction of distortion and improvement of illumination uniformity.
- Robust enclosure resistant to vibrations and shocks. Equipped with locking knobs for the iris and the focus.

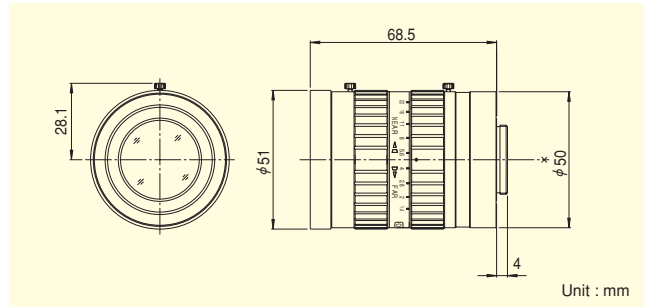

Focal Length (mm)		12.5
Iris Range		F1.4 ~ F22
Operation	Focus	Manual
	Iris	Manual
Angle Of View (H×V)	2/3"	38°47' × 29°35'
	1/2"	28°43' × 21°44'
	1/3"	21°44' × 16°23'
Focusing Range (From Front Of The Lens) (m)		∞ ~ 0.1
Object Dimensions at M.O.D. (H×V) (mm)	2/3"	83 × 62
	1/2"	60 × 45
	1/3"	45 × 34
Back Focal Distance (in air) (mm)		16.07
Exit Pupil Position (From Image Plane) (mm)		-101
Filter Thread (mm)		M49 × 0.75
Mount		C
Mass (g)		285

Remarks

- With Metal Mount
- With Locking Knob for Iris and Focus



For FA/Machine Vision
Fixed Focal

HF16SA-1

Applicable camera (model)

1	2/3	1/2	1/3	1/4
---	-----	-----	-----	-----

- FIXED
Fixed Focal
- 5 Mega
For Megapixel Camera
- MANUAL
Manual Iris
- C-mt
C Mount
- METAL
Metal Mount
- F1.4
Wide Aperture Rate

NEW



- High-resolution design, providing support for up to 5 megapixel camera resolution.
- Rear focusing system provides improved performance in macro photography.
- Wide-aperture (F1.4) design achieves clear images under low light intensity.
- Enhanced image recognition accuracy achieved by reduction of distortion and improvement of illumination uniformity.
- Robust enclosure resistant to vibrations and shocks. Equipped with locking knobs for the iris and the focus.

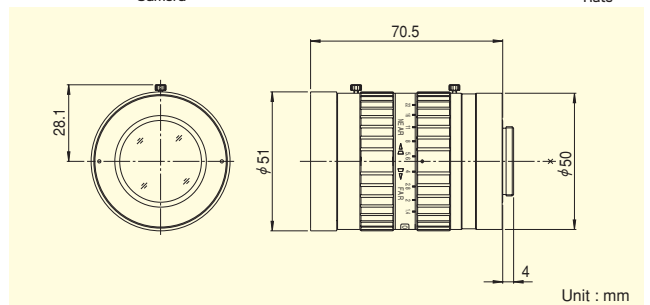

Focal Length (mm)		16
Iris Range		F1.4 ~ F22
Operation	Focus	Manual
	Iris	Manual
Angle Of View (H×V)	2/3"	30°45' × 23°18'
	1/2"	22°37' × 17°04'
	1/3"	17°04' × 12°50'
Focusing Range (From Front Of The Lens) (m)		∞ ~ 0.1
Object Dimensions at M.O.D. (H×V) (mm)	2/3"	69 × 51
	1/2"	50 × 37
	1/3"	37 × 28
Back Focal Distance (in air) (mm)		17.99
Exit Pupil Position (From Image Plane) (mm)		-172
Filter Thread (mm)		M49 × 0.75
Mount		C
Mass (g)		285

Remarks

- With Metal Mount
- With Locking Knob for Iris and Focus

FIXED FOCAL LENGTH LENSES